



For over 20 years, Mobile's OVER-SHOT WIRELINE CONTINUOUS SAMPLING SYSTEM has been recognized as the leading method for obtaining continuous samples while drilling in cohesive soils - fast, effective, hollow stem auger drilling and sample retrieval with the Overshot Retriever Assembly.

Whether it is used for identifying subsurface geological stratifications, environmental sampling, water well monitoring or retrieving high quality samples of unsaturated sand and gravel, this innovative system operates much more efficiently and faster than basic samplers where the rods must be tripped in and out for sample barrel retrieval.

The Overshot Wireline Sampling System is available in four sizes:

- 3-1/4" (83mm)
- 4-1/4" (108mm)
- 3-3/8" (86mm)
- 6-5/8" (168mm)

The 4-1/4" and 6-5/8" systems use identical retriever assemblies and can be purchased with or without this component.

A split barrel sampler can be used with the Overshot Wireline System. If no samples are required, the pilot bit extension assembly can be installed on the latching assembly replacing the bearing assembly and sampler, allowing for quick removal of the center pilot bit assembly while straight auger drilling.

In applications such as deep, underwater drilling, it may be necessary to substitute the Overshot Wireline System for the Drill Rod System. The hollow stem augers are drilled in the normal way with the sample barrel being held in place by drill rods attached to a bearing in the drive cap. Samples are then retrieved by tripping the drill rods out of the hole.

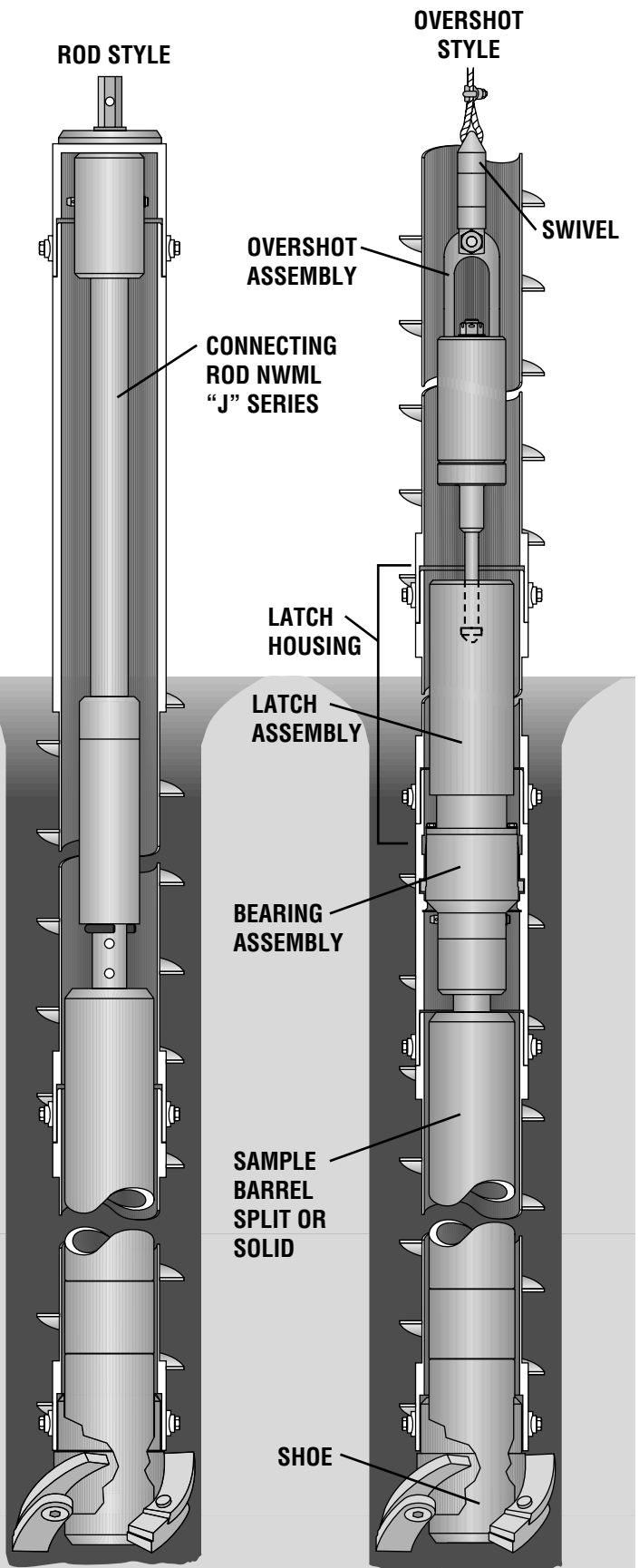



SPLIT BARREL SAMPLER ASSEMBLIES

Continuous Sampler Split Barrel Assemblies

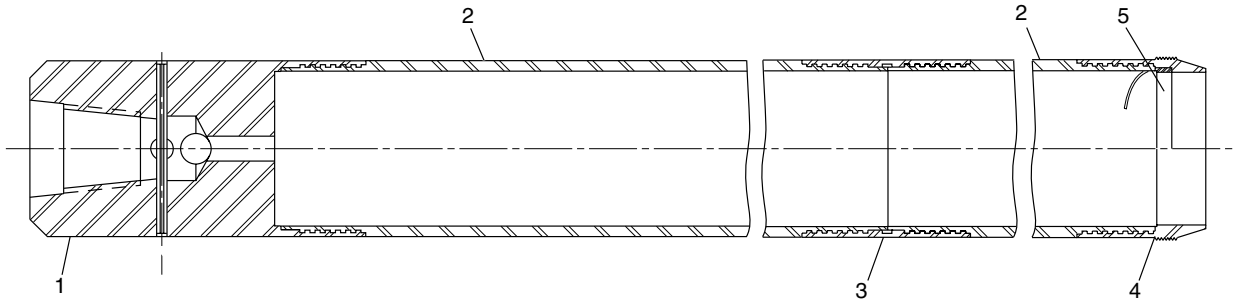

Continuous sample barrels are split into two 30" (762mm) sections joined by a center coupling for added strength. The complete assembly includes a head assembly, two 30" (762mm) barrel sections, a coupler, and a penetrating shoe. The shoe is hardened by a special heat treating process for longer life. Shoes are also provided to allow for sample retainers or for the use of clear plastic liners that help protect field crews operating in hazardous environments.

Sampler O.D.	Sampler I.D.	Sampler Length	Rod Connection	Assembly Part No.
3" (76.2mm)	2-1/2" (63.5mm)	30" (762mm)	NW	67034-16
3" (76.2mm)	2-1/2" (63.5mm)	60" (1.5m)	NW	67034-15
4" (102mm)	3-1/2" (89mm)	30" (762mm)	NWML	67040-01
4" (102mm)	3-1/2" (89mm)	60" (1.5m)	NWML	67040-02
6-1/4" (159mm)	5-3/4" (146mm)	30" (762mm)	NWML	67041-01
6-1/4" (159mm)	5-3/4" (146mm)	60" (1.5m)	NWML	67041-02

Ref. No.	Description	SAMPLERS								
		3" OD (76.2mm)			4" OD (102mm)			6-1/4" OD (159mm)		
		Part No.	Weight		Part No.	Weight		Part No.	Weight	
	lbs	kg		lbs	kg		lbs	kg		
1	Head Assy, w/ NW	67021-08	6	2.7	N/A	—	—	N/A	—	—
1	Head Assy, w/ NWML	N/A	—	—	67021-11	18	8.2	67021-05	24	10.9
2	30" (762mm) Split Barrel	67022-11	18	8.2	67022-12	23	10.4	67022-13	36	16.3
3	Coupler for 60" (1.5m) Lg. Barrel	190140	*	*	190179	2	.9	190180	3	1.4
4	Sampler Shoe	190071-08	2	.9	190071-25	2	.9	190071-18	4	1.8
5	Spacer (in place of basket trap)	190006-05	*	*	190006-06	*	*	190006-05	*	*
	Optional Accessories									
	Plastic Liner 30" (762mm) Lg.	190138-01	*	*	190138-03	2	.9	190138-02	3	1.4
	Basket Trap (Steel)	002419	*	*	190165-02	*	*	N/A	—	—
	Basket Trap (Plastic)	190177	*	*	190165-03	*	*			
	Flap Valve	002423	*	*	N/A	—	—	N/A	—	—
	Shoe (For Use with Plastic Liners)	190071-21	2	.9	190071-29	2	.9	190071-32	4	1.8

CONTINUOUS SAMPLING



3-1/4" (83mm) TRI-LOK and 3-3/8" (86mm) THREADED OVERSHOT WIRELINE SYSTEM

Used for continuous vertical profiling of the formation being drilled with our 3-1/4", 3-3/8" and 4" hollow stem auger sections. Short subs are added to vary the sample barrel lead setting to allow good recovery of samples throughout a broad range of formation types. The center plug can be locked in place to allow augering without adding center rods. The system can be easily converted to run **MOBILOK™** drill rod in lieu of a wireline if the formation requires.

NOTE: 4" Threaded System available. Consult Factory.

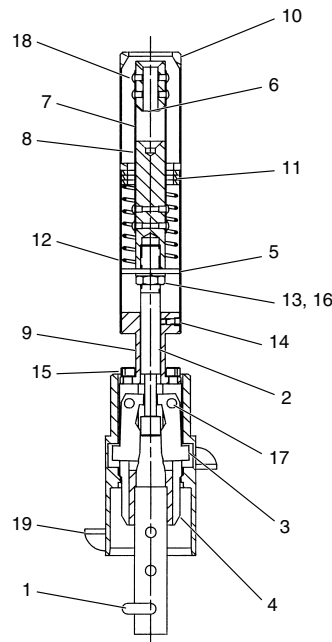

Latch Assembly

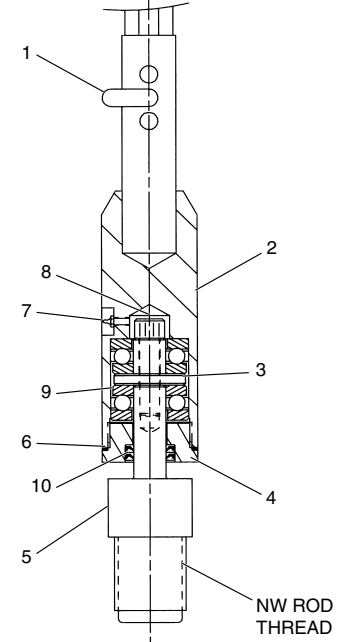

Bearing Assembly

Ref	Description	3-1/4" (83mm) System				3-3/8" (86mm) System			
		Req.	Part No	Weight		Req.	Part No	Weight	
				Lb.	Kg.			Lb.	Kg.
	COMPLETE SYSTEM (Includes latch, bearing and pilot bit assemblies, overshot retriever and accessories.)	1	67029-07	207	93.9	1	67029-08	216	98.0
	Latch Assembly	1	67020-09	51	23.1	1	67020-09	53	24.0
1	U-Pin (1500 series)	1	001306	1	0.5	1	001306	1	0.5
2	Latch Plunger	1	190008	2	0.9	1	190008	2	0.9
3	Latch	2	190009-02	1	0.5	2	190009-02	1	0.5
4	Latch Body	1	190011	14	6.4	1	190011	14	6.4
5	Washer	2	190053	1	0.5	2	190053	1	0.5
6	Latch Blank (set)	1	190057	1	0.5	1	190057	1	0.5
7	Spring	4	190058	1	0.5	4	190058	1	0.5
8	Overshot Bar	1	190059	4	1.8	1	190059	4	1.8
9	Guide	1	190060	4	1.8	1	190060	4	1.8
10	Spring Housing	1	190061	3	1.4	1	190061	3	1.4
11	Spacer	3	210032-28	1	0.5	3	210032-28	1	0.5
12	Compression Spring	1	212160-03	1	0.5	1	212160-03	1	0.5
13	Lockwasher	1	3126-0016	*	*	1	3126-0016	*	*
14	Hex Socket Head Capscrew	8	3130-0012	*	*	8	3130-0012	*	*
15	Hex Socket Head Capscrew	4	3130-0071	*	*	4	3130-0071	*	*
16	Hex Jam Nut	1	3204-0016	*	*	1	3204-0016	*	*
17	Dowel Pin	2	3229-0057	1	0.5	2	3229-0057	1	0.5
18	Button Head Capscrew	16	3559-0002	1	0.5	16	3559-0002	1	0.5
19	Latch Housing	1	190023	15	6.8	1	190010	17	7.7
	Bearing Assembly	1	67020-11	23	10.4	1	67020-11	23	10.4
1	U-Pin (1500 series)	1	001306	*	*	1	001306	*	*
2	Bearing Housing	1	190013	12	5.4	1	190013	12	5.4
3	Bearing Spacer	1	190015	1	0.5	1	190015	1	0.5
4	Housing Seal	1	190016	2	0.9	1	190016	2	0.9
5	Sampler Hanger	1	190080	6	2.7	1	190080	6	2.7
6	Shim	3	210091-12	*	*	3	210091-12	*	*
7	Grease Fitting	1	3129-0001	*	*	1	3129-0001	*	*
8	Hex Socket Head Capscrew	1	3137-0099	*	*	1	3137-0099	*	*
9	Ball Bearing	2	3535-0002	2	0.9	2	3535-0002	2	0.9
10	Oil Seal (Single Lip)	2	3560-0011	*	*	2	3560-0011	*	*

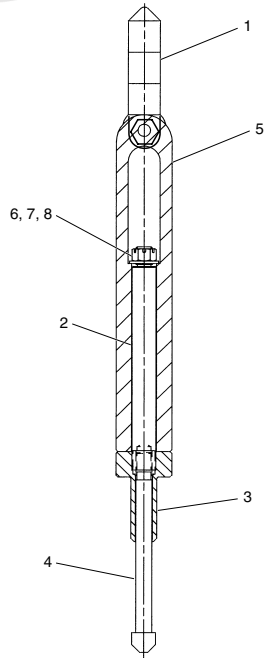

Overshot Retriever Assembly

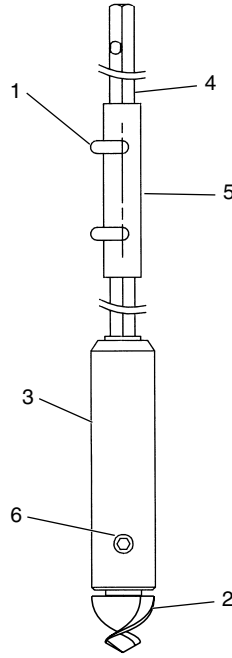

Pilot Bit Assembly

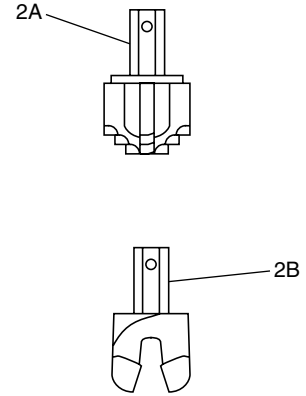

Pilot Bits

Ref	Description	3-1/4" (83mm) System			3-3/8" (86mm) System		
		Part No	Weight		Part No	Weight	
			Lb.	Kg.		Lb.	Kg.
	Overshot Retriever Assembly	67020-10	39	17.7	67020-11	39	17.7
1	Ball Bearing Swivel	006305	7	3.2	006305	7	3.2
2	Lift Rod	190054	5	2.3	190054	5	2.3
3	Latch Key	190055	4	1.8	190055	4	1.8
4	Spear	190056	3	1.4	190056	3	1.4
5	Latch Weight	190063	27	12.2	190063	27	12.2
6	Cotter Pin	3194-0038	*	*	3194-0038	*	*
7	Flatwasher	3198-0012	*	*	3198-0012	*	*
8	Hex Slotted Nut	3208-0012	*	*	3208-0012	*	*
	Pilot Bit Assembly	67020-12	39	17.7	67020-12	39	17.7
1	U-Pin (1500 series)	001306	*	*	001306	*	*
2	Pilot Bit 2-3/8" (60mm) x 1-1/8" (29mm) Hex Shank	005503	2	0.9	005503	2	0.9
3	Pilot Bit Plug	190019	33	15	190019	33	15
4	Hex Bar Extension 1-1/8" (29mm) x 3 ft (.9m)	190015	1	.5	190015	1	0.5
5	Hex Sleeve	190116	3	1.4	190116	3	1.4
6	Hex Socket Head Capscrew	3130-0080	*	*	3130-0080	*	*
	Accessories						
	Hex Bar 1 ft 3 in (381mm) long	190095	2	0.9	190095	2	0.9
	3 ft (.91m) Auger	150288-02	47	21.3	150363-02	58	26.3
	Brass Cutterhead Bushing	210021-08	2	0.9	210031-04	2	0.9
	Optional Equipment						
2a	Pilot Bit - Step Type 3" (76.2mm) x 1-1/8" (29mm) Hex Shank	150574-01	2	0.9	150574-01	2	0.9
2b	Pilot Bit - 2 Prong 3" (76.2mm) x 1-1/8" (29mm) Hex Shank	200024	2	0.9	200024	2	0.9

4-1/4" (108mm) TRI-LOK & 6-5/8" (168mm) TRI-LOK OVERSHOT WIRELINE SYSTEM

Used for continuous vertical profiling of the formation being drilled with our 4-1/4" (108 mm) and 6-5/8" (168 mm) hollow stem auger sections. Short subs are added to vary the sample barrel lead setting to allow good recovery of samples throughout a broad range of formation types. The center plug can be locked in place to allow augering without adding center rods. The system can be easily converted to run **MOBILOK** drill rod in lieu of a wireline if the formation requires.

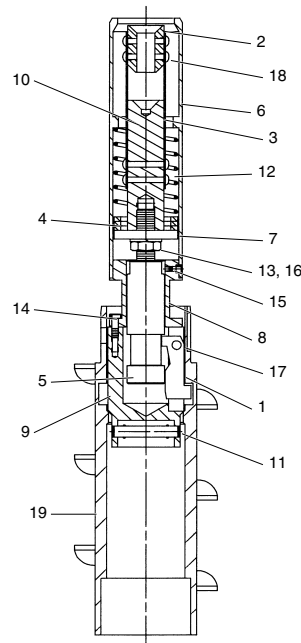

Latch Assembly

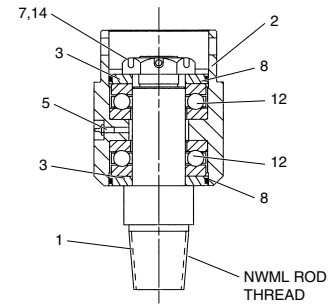

6-5/8" Bearing Assembly

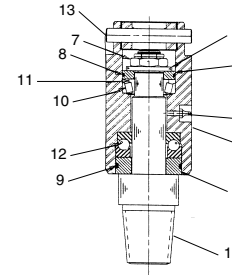

4-1/4" Bearing Assembly

Ref.	Description	4-1/4" (108mm) TRI-LOK				6-5/8" (168.3mm) TRI-LOK			
		Req.	Part No	Weight		Req.	Part No	Weight	
				Lb.	Kg.			Lb.	Kg.
	COMPLETE SYSTEM (Includes latch, bearing and pilot bit assemblies, overshot retriever and accessories.)		67029-09	237	107.5		67029-10	352	159.7
	Latch Assembly		67020-05	95	43.1		67020-08	166	75.3
1	Latch	2	190009-02	1	0.5	1	190009-02	1	0.5
2	Latch Spear	4	190118-01	1	0.5	1	190118-01	1	0.5
3	Overshot Bar	1	190125	7	3.2	1	190125	7	3.2
4	Spring	4	190128	1	0.5	4	190128	1	0.5
5	Latch Plunger	1	190152	7	3.2	1	190182	15	6.8
6	Spring Housing	1	190154	10	4.5	1	190154	10	4.5
7	Washer	1	190157	1	0.5	1	190157	1	0.5
8	Guide	1	190158	4	1.8	1	190181	17	7.7
9	Latch Body	1	190184	12	5.4	1	190110	23	10.4
10	Spacer	3	210032-61	1	0.5	3	210032-61	1	0.5
11	Detent Ball Pin	1	210033-91	1	0.5	1	210033-54	1	0.5
12	Compression Spring	1	212160-05	2	0.9	1	212160-05	1	0.5
13	Lockwasher	1	3126-0016	*	*	1	3126-0016	*	*
14	Hex Socket Head Capscrew	1	3130-0062	*	*	4	3130-0063	*	*
15	Hex Socket Head Capscrew	6	3133-0007	1	0.5	6	3133-0007	1	1
16	Hex Jam Nut	1	3204-0016	*	*	1	3204-0016	*	*
17	Dowel Pin	2	3229-0057	1	0.5	3	3068-0244	*	*
18	Button Head Capscrew	16	3559-0003	1	0.5	16	3559-0003	1	1
19	Latch Housing	1	190146	44	20.0	1	190108	86	39.0
	Bearing Assembly		67020-15	27	12.2		67020-04	24	10.9
1	Bearing Shaft w/ NWML thread	1	190189	7	3.2	1	190111	12	5.4
2	Bearing Carrier	1	190194-10	12	5.4	1	190114	8	3.6
3	Washer	1	190191	1	0.5	2	190121	1	1
4	Washer	1	190192	1	0.5		N/A	—	—
5	Grease Fitting	1	3129-0001	*	*	1	3129-0001	*	*
6	Flat Washer	1	3198-0016	*	*		N/A	—	—
7	Hex Nut	1	3230-0003	1	0.5	1	3230-0009	1	1
8	O-Ring	1	3538-0138	1	0.5	2	3538-0238	*	*
9	O-Ring	1	3538-0231	1	0.5		N/A	—	—
10	Cone, Taper Roller Bearing	1	3231-0040	1	0.5		N/A	—	—
11	Cup, Taper Roller Bearing	1	3232-0040	1	0.5		N/A	—	—
12	Thrust Ball Bearing	1	3535-0004	1	0.5	2	3535-0003	1	0.5
13	Detent Ball Pin	1	210033-91	1	0.5	1	210333-54	1	0.5
14	Cotter Pin					1	3194-0086	*	*

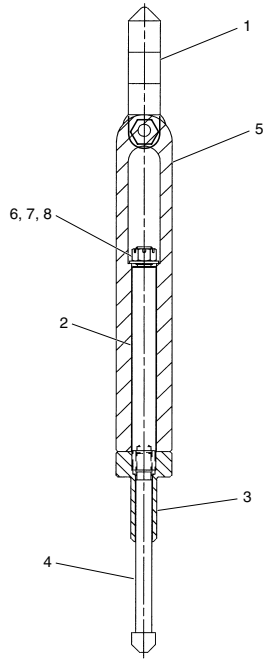

Overshot Retriever Assembly

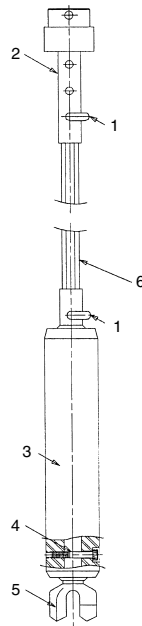

Pilot Bit Assembly

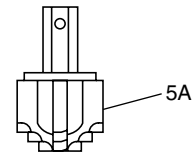

Pilot Bit

Ref.	Description	4-1/4" (108mm) TRI-LOK				6-5/8" (168.3mm) TRI-LOK			
		Req.	Part No	Weight		Req.	Part No	Weight	
				Lb.	Kg.			Lb.	Kg.
Overshot Retriever Assembly			67020-06	50	22.7		67020-06	45	20.4
1	Ball Bearing Swivel	1	006305	7	3.2	1	006305	7	3.2
2	Lift Rod	1	190129	6	2.7	1	190129	6	2.7
3	Spear	1	190131	3	1.4	1	190131	3	1.4
4	Latch Weight	1	190159	29	13.2	1	190159	29	13.2
5	Latch Key	1	190161	5	2.3	1	190161	5	2.3
6	Cotter Pin	1	3194-0086	*	*	1	3194-0086	*	*
7	Flatwasher	1	3198-0016	*	*	1	3198-0016	*	*
8	Hex Slotted Nut	1	3208-0016	*	*	1	3208-0016	*	*
Pilot Bit Assembly			67020-13	52	23.6		67020-14	104	47.2
1	U-Pin (1500 series)	2	001306	1	0.5	1	001307	1	0.5
2	Latch Body To Hex Adapter	1	190188	9	4.1	1	190134	15	6.8
3	Pilot Bit Plug	1	190143-01	39	17.7	1	190132	80	36.3
4	Hex Socket Head Capscrew	1	3130-0118	1	0.5	1	3130-0170	1	0.5
5	Pilot Bit	1	004304	2	0.9	1	004950	7	3.2
6	Shank Extension — 1-1/8" (41mm)	1	190144-01	7	3.2				
6	Shank Extension — 1-5/8" (51mm)					1	190133-01	10	4.5
Accessories									
	4 3/4" (121mm) lg NWML Extension		180012-14	6	2.7		180012-14	6	2.7
	3" (76mm) lg NWML Extension		180012-27	3	1.4		180012-27	3	1.4
	Brass Cutterhead Bushing		210031-12	4	1.8		210031-10	4	1.8
Optional Equipment									
5A	3-Step Carbide Insert Step Pilot Bit		150574-02	4	1.8		150574-03	4	1.8
	Cutterhead Assembly To Accept Brass Bushing		61032-02	21	9.5		61032-03	33	15.0
	16" (406mm) lg Hollow Stem Auger Extension		150329-08	15	6.8		150329-07	44	20
	30" (762mm) lg NWML Drill Rod		180386-13	13	5.9		180386-13	13	5.9

Drill Rod Continuous Sampling Systems

The rod system continuous sampling method incorporates many of the same components as the wireline system, but allows you to be more efficient in situations where you encounter heaving sands. The two systems are interchangeable and provide the operator with maximum versatility. The Mobile system does not require special hex rods. It utilizes standard "J" series or the premier **MOBILOK** NWML line.

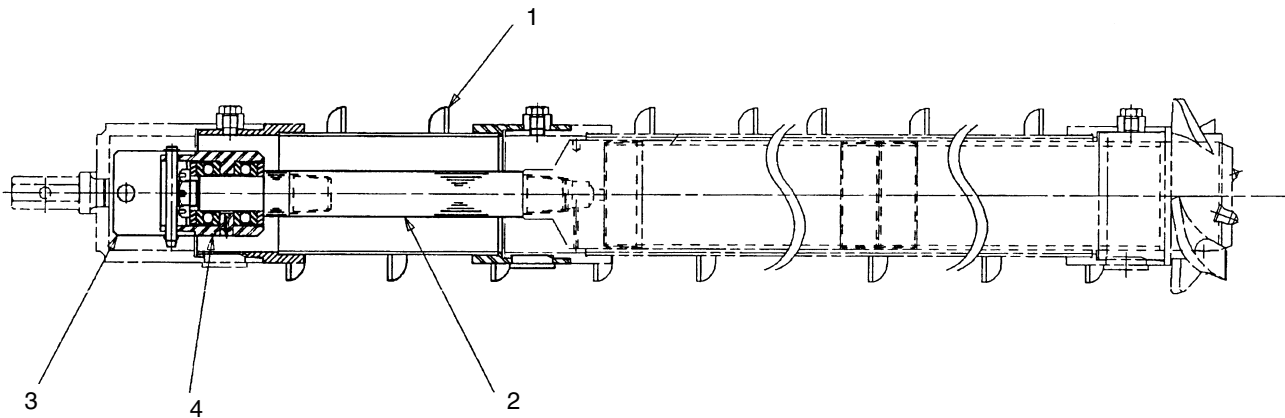

Ref	Description	4-1/4" (108mm) System			6-5/8" (168mm) System		
		Part No	Weight		Part No	Weight	
			Lb.	Kg.		Lb.	Kg.
	Overshot Retriever Assembly Includes all parts listed below	67042-25	125	56.7	67042-27	175	79.4
1	Auger, HS x 2 ft (61mm) long	150329-17	46	21	150329-18	88	40
2	NWML Box to NWML Pin X 8-1/2" (216mm) long	180012-38	3	1.4			
2	NWML Box to NWML Pin x 13-11/16" (348mm) long				180012-39	5	2.3
3	Rod to cap Adapter	217247	7	3.2	217248	15	6.8
4	Bearing Assembly	67020-15	20	9.1	67020-04	27	12.2
	Adapter, NWML Box to NWML Pin x 4-3/4" (121mm) long	180012-14	5	2.3	180012-14	5	2.3
	Adapter, NWML Box to NWML Pin x 3" (76mm) long	180012-27	3	1.4	180012-27	3	1.4
	Conversion Parts – Wireline System to Rod System						
	Complete Assembly to Convert Wireline System to Rod System	67042-28	105	47.6	67042-29	145	65.8
	Auger, HS x 2 ft (61mm) long	150329-17	46	21	150329-18	88	40
	Sub, NWML Box to NWML Pin x 8-1/2" (216mm) long	180012-38	3	1.4			
	Sub, NWML Box to NWML Pin x 13-11/16" (348mm) long				180012-39	5	2.3
	Rod to Cap Adapter	217247	7	3.2	217248	15	6.8