

FIGURE 5-17. Isometric drawing of Hollow-Stem Auger with the Center Drag Bit, Which Can Be Used with Soil Sampling Devices (after Acker 1974)

ground surface. To operate, the sampler with compressed air bell was lowered to the bottom of a cleaned borehole. The sampling tube was pushed out of the air bell and into the undisturbed soil. After the drilling rods had been disconnected from the sampler and removed from the borehole, compressed air was pumped into the bell. When air bubbles began rising to the surface through the drilling fluid, all of the drilling fluid had been forced out of the compressed air bell. The sampling tube with the sample was pulled from the in situ formation into the bell, and the entire assembly was quickly returned to the ground surface by a cable. Bishop used the principles of arching and capillary stresses at the air-water interface of the sand to retain the sample in the tube and to reduce sample losses.

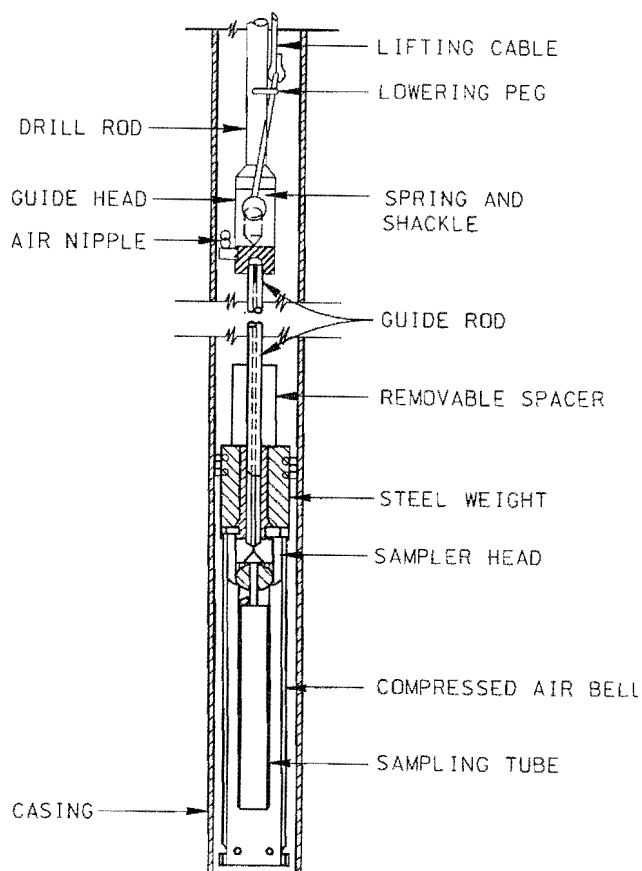

FIGURE 5-18. Bishop Sand Sampler (after Hvorslev 1949)

Vibratory samplers have been used to obtain samples of saturated fine sands and silts. The principle of sampling by vibratory methods consists of liquefying the material in the immediate proximity of the sampling rather than applying brute force to advance the tube. Because of the liquefaction of the material near the sampling tube, the sample is severely disturbed. Consequently, the vibratory sampling method is not satisfactory for obtaining undisturbed samples of sands.

5-5. Sample Tubes

a. Diameter

The size of specimen required for the laboratory testing program dictates the minimum acceptable sample tube diameter (shown in Chapter 2, Table 2-5). Generally, a tube with an ID of 125 mm (5 in.) should be used for sampling cohesive soils, whereas a tube with an ID of 75 mm (3 in.) should be used for sampling cohesionless soils. Figure 5-20 is a photograph of sampling tubes 75 and 125 mm (3 and 5 in.) in diameter. The smaller diameter tubes are normally used for sampling cohesionless materials because the penetration resistance of the

b. Sand samplers

Obtaining undisturbed samples of sand has been rather difficult and elusive. In general, the in situ stresses are relieved by sampling operations, and frequently, the sand structure has been disturbed and sometimes destroyed. Hvorslev (1949) suggested several methods including the use of thin-walled fixed-piston samplers in mudded holes, open-drive samplers using compressed air, in situ freezing, and impregnation. The U.S. Army Engineers Waterways Experiment Station (1952) and Marcuson and Franklin (1979) reported that loose samples were densified and that dense samples were loosened when the thin-walled fixed-piston sampler was used. Seed et al. (1982) reported that the Hvorslev fixed-piston sampler caused density changes, whereas the advanced trimming and block sampling technique caused little change in density, although some disturbance due to stress relief was reported. Singh, Seed, and Chan (1982) reported a laboratory study that indicated that the in situ characteristics, including the applied stress conditions, could be maintained in a sandy soil if the material was frozen unidirectionally without impedance of drainage and sampled in a frozen state. Equipment and procedures for drilling and sampling in frozen formations are presented in Chapter 9; suggested equipment and procedures for artificial freezing of in situ deposits of cohesionless soils are presented in Appendix D. Schneider, Chameau, and Leonards (1989) conducted a laboratory investigation of the methods of impregnating cohesionless soils. They reported that the impregnating material must readily penetrate the soil and must be easily and effectively removed at a later date. Because of these limitations, they also concluded that although the impregnation method could be used in the field environment, the methodology was better suited to the laboratory environment.

Bishop (1948) developed a thin-walled open-drive sampler with a diameter of 63 mm (2-1/2 in.) that was specifically designed for sampling sand. The sampler was equipped with vents and a diaphragm check valve. Figure 5-18 is a schematic diagram of the Bishop sand sampler. A drawing that illustrates the operation of the Bishop sampler is presented in Figure 5-19. The entire sampler was encapsulated in a compressed air bell that was connected to an air compressor at the



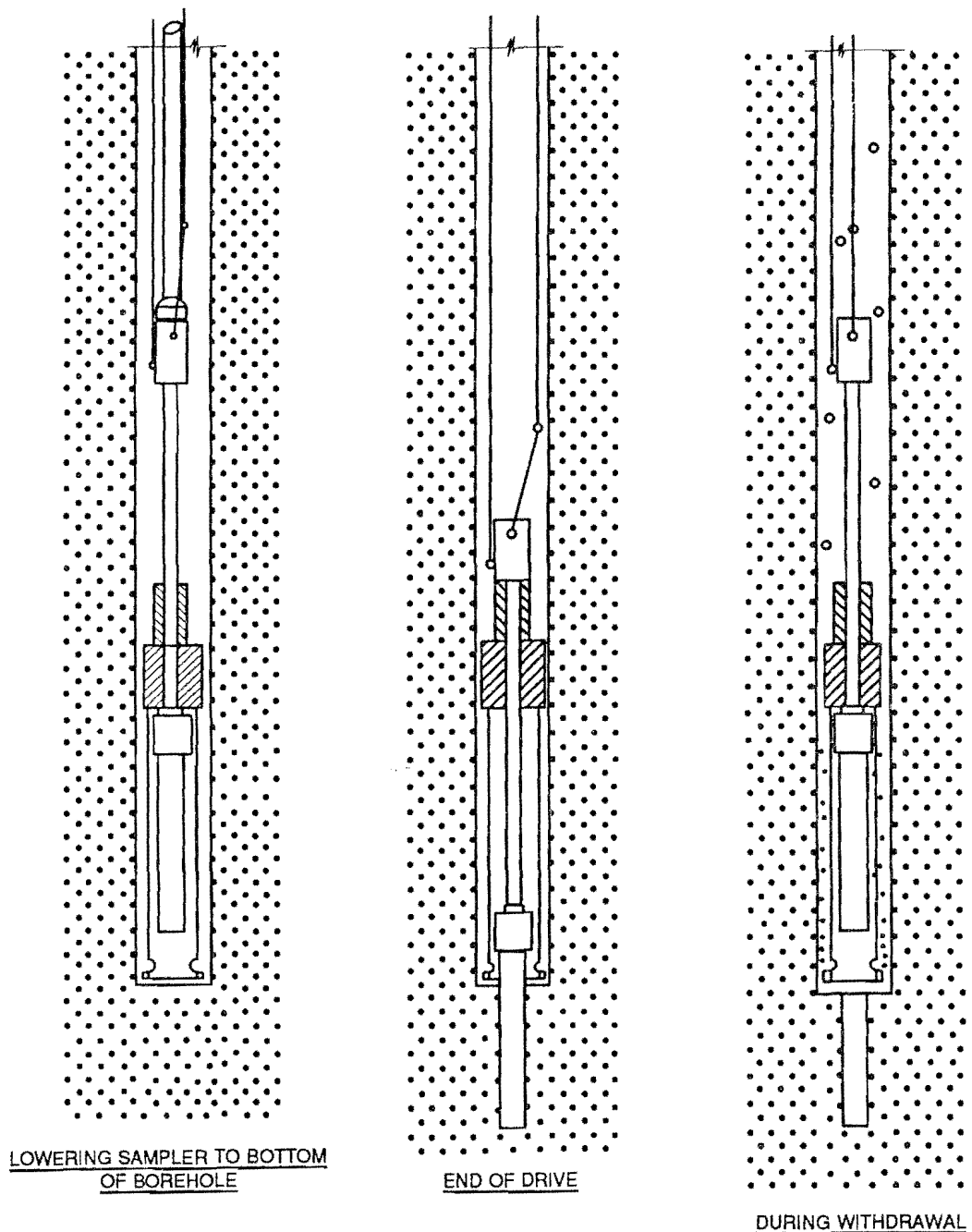

FIGURE 5-19. Operation of Bishop Sand Sampler (after Hvorslev 1949)

125-mm (5-in.) tubes in dense cohesionless soils generally exceeds the driving capacity of the drill rig. Furthermore, the sample recovery ratio for cohesionless materials is frequently higher when the tube with an ID of 75 mm (3 in.) is used because of arching of the material in the sample tube. Although larger samples are sometimes required for special testing programs, sampling tubes with diameters of 75 and 125 mm (3 and 5 in.) should be used to the extent possible to permit standardization of sampling equipment and procedures

and to ensure that sample sizes are compatible with laboratory testing equipment and requirements.

b. Length

Sample tubes must be long enough to accommodate the sampler head and piston of the given sampling apparatus and to obtain a sufficient length of sample. Typically, the length of the sample tube is about 0.9 m (3 ft), which is sufficient for obtaining a sample 0.75 m (2-1/2 ft) long.

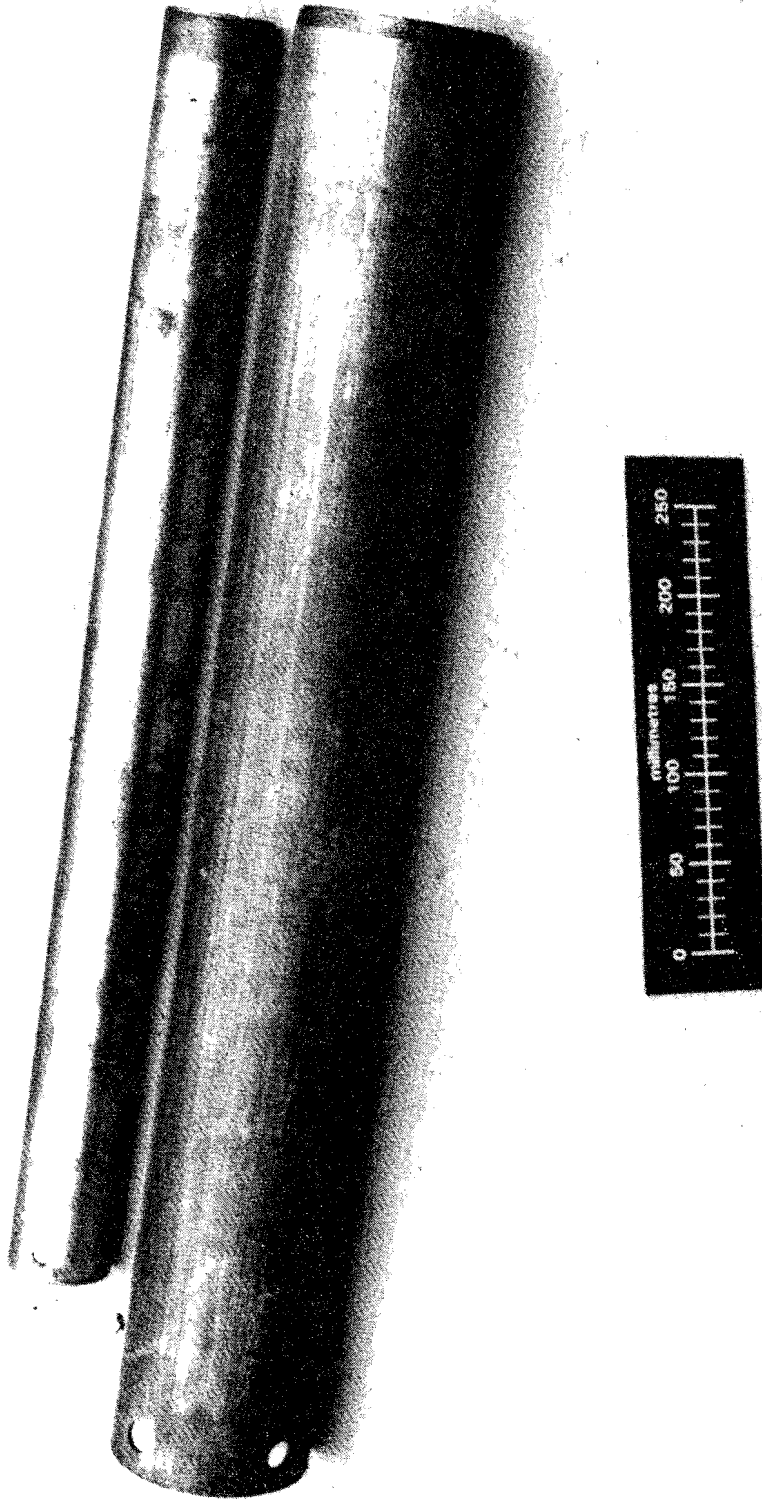

FIGURE 5-20. Sampling Tubes, 75 mm (3 in.) and 125 mm (5 in.) in Diameter

c. Area ratio

As discussed in Chapter 2, Section 2-3, the sample tube wall should be as thin as practical but strong enough to prevent buckling of the tube during sampling. Sample tubes of 125-mm (5-in.) ID by 11-gauge (3-mm) wall thickness or 75-mm (3-in.) ID by 16-gauge (1.5-mm) wall thickness cold-drawn or welded and drawn-over-the-mandrel seamless steel tubing provide adequate strength and an acceptable area ratio. The area ratio for a sample tube of 125-mm (5-in.) ID by 11-gauge (3-mm) with a 1.0 percent swage is approximately 12 percent. The area ratio for a sample tube of 75-mm (3-in.) ID by 16-gauge (1.6-mm) with 0.5 percent swage is approximately 10 percent.

d. Cutting edge

The sample tube for undisturbed samples should have a smooth, sharp cutting edge, free from dents and nicks. The cutting edge should be formed to cut a sample 0.5 to 1.5 percent smaller than the inside diameter of the sample tube. As discussed in Chapter 2, Section 2-3, the required clearance ratio, or swage, must be varied for the character of the soil to be sampled. Sticky, cohesive soils require the greatest clearance ratio. However, swage should be kept to a minimum to allow 100-percent sample recovery.

e. Material

Tubing. Sampling tubes should be clean and free of all surface irregularities, including projecting weld seams.

Cold-drawn seamless steel tubing provides the most practical and satisfactory material for sample tubes. Generally, tubing with a welded seam is not satisfactory. However, welded and drawn-over-a-mandrel steel tubing is available with dimensions and roundness tolerances satisfactory for sample tubes. Brass or stainless steel tubing is also satisfactory, provided that acceptable tolerances are maintained. However, the extra cost for brass or stainless steel tubing is justified only for special projects.

Coating. Steel sampling tubes should be cleaned and covered with a protective coating to prevent rust and corrosion, which can damage or destroy both the unprotected tube and sample. The severity of the damage is a function of time as well as the interaction between the sample and the tube. Hence, the material to be sampled may influence the decision regarding the type of coating that is selected. It is also noteworthy that the protective coating helps to form a smoother surface, which reduces the frictional resistance between the tube and the soil during sampling operations.

Coatings may vary from a light coat of oil, lacquer, or epoxy resin to Teflon or plating of the tubes. Alternate base metals for the tubes should also be considered for special cases. Mathews (1959) describes the results of tests conducted at WES on a variety of sample tube coatings. A photograph of a dipping tank for coating sampling tubes with diameters of 75 and 125 mm (3 and 5 in.) is illustrated in Figure 5-21.