

GT8

Geotechnical Drill Rig.
Compact and sturdy design
to harness the power
of a drilling rig in a
multifunction drill.



SPECIFICATIONS

Max. torque	9,303 ft.-lbs. (12,613 Nm)
Max. rotation speed	965 rpm
Push and pull capacity	26,835 lbs (12,172 kg)
Control panel with adjustable height	20 in. (508 mm) hydraulically
Open spindle head	4.9 in. (124 mm)
Head sliding clearance	16 in. (406 mm)
Front-rear slide mast	16 in. (406 mm)
Left-right slide mast	6 in. (152 mm)
Hydraulic percussion hammer option	With quick setup system
NWL diamond core drilling capacity	1,970 ft. (600 m)
Rig weight (without track carrier option)	19,250 lbs. (8,730 kg)

FEATURES AND BENEFITS

- Best-in-class torque - Max. speed combo
- Best-in-class for depth in NWL core
- Reliable and simple components for affordable maintenance and continued operations under all conditions



GT8

GEOTECHNICAL DRILL RIG

Power unit <small>(other options available on request)</small>	
Diesel engine (standard)	Deutz Tier 3 Turbo (4 cyl. water-cooled)
Horsepower	131 hp (97 kW) @ 2,400 rpm
Torque	286 ft.-lbs. (387 Nm) @ 2,400 rpm
Operation angle	0 to 45 degrees
Fuel tank	50 US gal (190 L)

Hydraulic system	
Hydraulic pump (2) <small>(max. L/min - gal/min)</small> <small>(max. psi - bar)</small>	191 L/min (42 US gal/min) @ 2,400 rpm (4,500 psi [310 bar])
	91 L/min (20 US gal./min) @ 2,400 rpm (3,500 psi [241 bar])
Pressurized hydraulic oil tank	45 US gal. (170 L)
Oil heat exchanger	Air cooling
Filtration	10 micron filter on return line
Control panel (adjustable height)	20 in. (508 mm) hydraulically
Leveling jacks (4)	42 in. (1,067 mm) stroke

Rotary head	
Final drive	HV 80-4 chain in an oil bath
Hydraulic motor	160 cc variable
Transmission	HI-LO 2-speed mechanic
Rotary head ratio	2.1:1
Open spindle	4.9 in. (124 mm)
Lubrication	Pump-pressurized with filter
Speed	0 to 965 rpm

* Rotary chuck	
Holding capacity	38,000 lbs. (17,236 kg)
Spindle interior diameter	4.9 in. (124 mm) PWL rod
Operation	Spring-closed and hydraulically opened

2-speed transmission			
Speed	Ratio	RPM	Maximum Torque
LO	7.4:1	0-250	9,303 ft.-lbs. (12,613 Nm) @ 62 rpm
HI	1.9:1	0-950	598 ft.-lbs. (810 Nm) @ 965 rpm

Speed and torque based on a 160 cc variable hydraulic motor at 4,500 psi (310 bar)

Feed mast short <small>(Feed mast with 13 ft. of stroke is available)</small>	
Head stroke	68 in. (1.72 m) hydraulically with chain
Mast stroke	60 in. (1.52 m) hydraulically
Head sliding clearance	16 in. (406 mm) Hydraulically
Push and pull speed	0-135 ft./min (0-41 m/min) @ 4,500 psi
Push and pull capacity	26,835 lbs. (12,172 kg) @ 4,500 psi
Possible angle	45 to 90 degrees
Rod pull length	10 ft. (3 m) / 20 ft. (6 m) with extension
Front-rear slide mast	16 in. (406 mm) displacement
Left-right slide mast	6 in. (152 mm) displacement

* Rod clamp	
Holding capacity	25,000 lbs. (11,340 kg)
Diameter capacity max.	11 in. (279 mm)
Operation	Two opposing hydraulic cylinders
Extensible clamp support : stroke	30 in. (762 mm) hydraulically
Extensible clamp support : pull/push	15,000 lbs. (6,803 kg) capacity

* Wireline hoist with hydraulic cable guide	
Cable capacity (3/16 in. / 1/4 in.)	2,130 ft. (650 m) / 1,150 ft. (350 m)
Empty pull capacity	2,500 lbs. (1,135 kg)
Full pull capacity	650 lbs. (295 kg)

* Main hoist	
Capacity	9,000 lbs. (4,082 kg)
Cable diameter	1/2 in. (12.7 mm)
Cable capacity	100 ft. (30 m)

* Auxiliary hoist	
Capacity	3,000 lbs. (1,360 kg)
Cable diameter	3/8 in. (9.52 mm)
Cable capacity	100 ft. (30 m)

* Traction hoist (synchronized with tracks)	
Capacity	25,000 lbs. (11,340 kg)
Cable diameter	9/16 in. (14.28 mm)
Cable capacity	100 ft. (30 m)

Operating capacity		
Hollow stem augers	4-1/4 in. (108 mm) ID	150 ft. (45.7 m)
Continuous flight auger	6 in. (152.4 mm) OD	260 ft. (79.2 m)
Rotary drilling	NWJ/NW drill pipe	1,250 ft. (381 m)
Diamond core <small>* Recommended size for maximum performance</small>	B 2-3/16 in. (55.6 mm)	2,625 ft. (800 m)
	N 2-3/4 in.* (69.9 mm)	1,970 ft. (600 m)
	H 3-1/2 in.* (88.9 mm)	1,065 ft. (325 m)
	P 4-5/8 in. (117.5 mm)	575 ft. (175 m)
Drilling capacity is calculated on a 90-degree down hole and will depend on in-hole tools, ground conditions, drilling techniques and equipment used.		

ALSO AVAILABLE (* OPTIONS)

- Hydraulically operated SPT automatic hammer
140 lbs (64 kg) or 300 lbs (136 kg)
- Auger guide frame with variety of removable guide
- Hydraulic breakout wrench
- Cathead hoist
- Hydraulic percussion hammer
- Water pump type FMC and/or Moyno
- Track carrier with blade option and rod rack option

DIMENSIONS

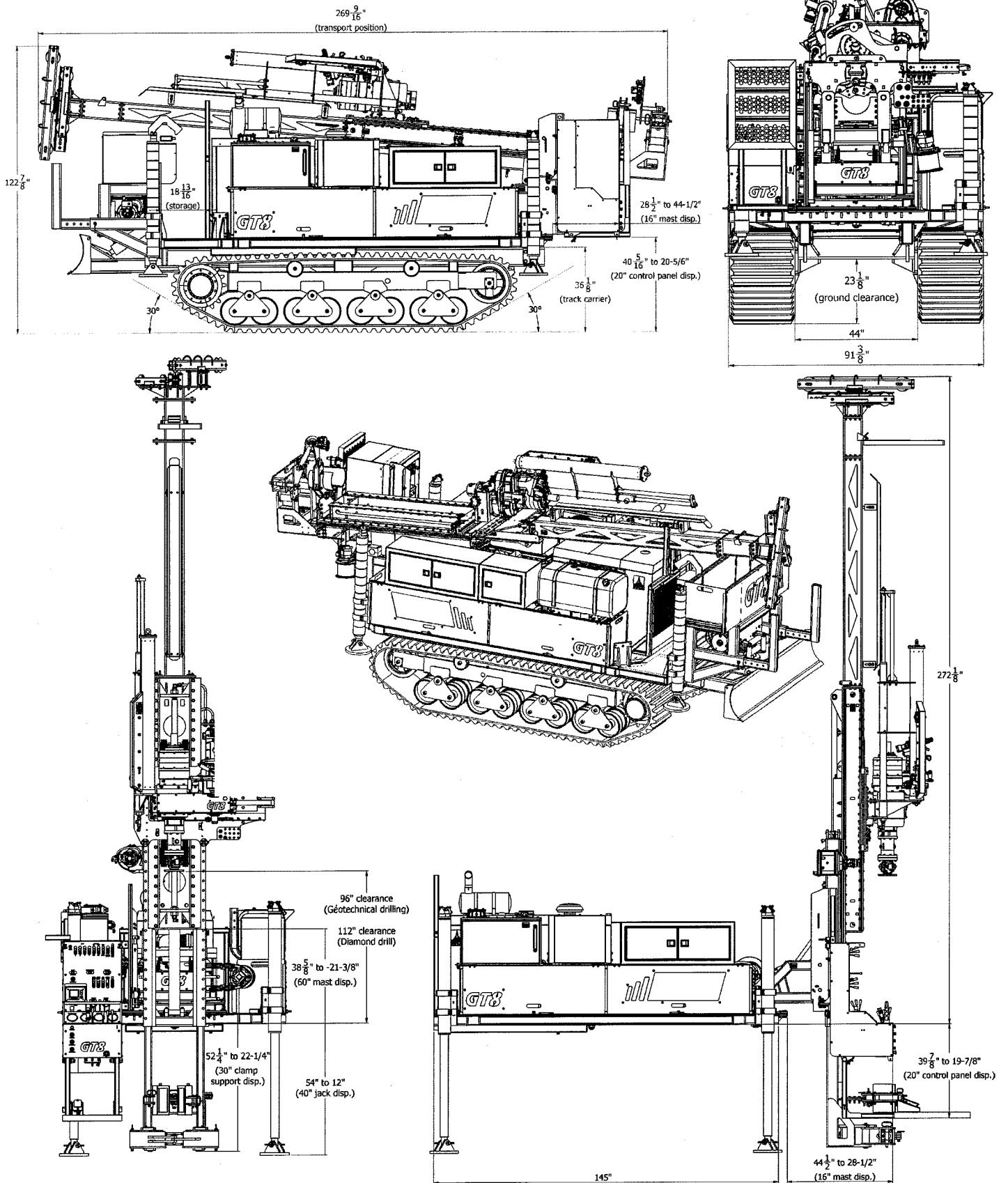

Materials and specifications are subject to change without notice.

Field experience. Real experience.



Distributor:

240, rue Gilbert-Bosse, Val-d'Or, QC, Canada J9P 0H4

1 819 874-4404 info@gtechdrill.com

gtechdrill.com